



Most Widely Accepted and Trusted

# ICC-ES Evaluation Report

# ESR-2114

ICC-ES | (800) 423-6587 | (562) 699-0543 | www.icc-es.org

Reissued 10/2017  
This report is subject to renewal 10/2018.

**DIVISION: 06 00 00—WOOD, PLASTICS AND COMPOSITES**  
**SECTION: 06 05 23—WOOD, PLASTIC, AND COMPOSITE FASTENINGS**

**REPORT HOLDER:**

**SCREW PRODUCTS, INC.**

**9401 54<sup>TH</sup> AVENUE NW, BUILDING 1B  
GIG HARBOR, WASHINGTON 98332**

**EVALUATION SUBJECT:**

**DECKLOK BRACKET**



Look for the trusted marks of Conformity!

*“2014 Recipient of Prestigious Western States Seismic Policy Council (WSSPC) Award in Excellence”*



A Subsidiary of

*ICC-ES Evaluation Reports are not to be construed as representing aesthetics or any other attributes not specifically addressed, nor are they to be construed as an endorsement of the subject of the report or a recommendation for its use. There is no warranty by ICC Evaluation Service, LLC, express or implied, as to any finding or other matter in this report, or as to any product covered by the report.*



# ICC-ES Evaluation Report

**ESR-2114**

Reissued October 2017

This report is subject to renewal October 2018.

[www.icc-es.org](http://www.icc-es.org) | (800) 423-6587 | (562) 699-0543

A Subsidiary of the International Code Council®

**DIVISION: 06 00 00—WOOD, PLASTICS AND COMPOSITES**  
**Section: 06 05 23—Wood, Plastic, and Composite Fastenings**

**REPORT HOLDER:**

**SCREW PRODUCTS, INC.**  
9401 54<sup>TH</sup> AVENUE NW, BUILDING 1B  
GIG HARBOR, WASHINGTON 98332  
(877) 844-8880  
[www.screw-products.com](http://www.screw-products.com)  
[info@screw-products.com](mailto:info@screw-products.com)

**EVALUATION SUBJECT:**

**DECKLOK BRACKET**

**1.0 EVALUATION SCOPE**

**Compliance with the following codes:**

- 2012, 2009 and 2006 *International Building Code*® (IBC)
- 2012, 2009 and 2006 *International Residential Code*® (IRC)

**Property evaluated:**

Structural

**2.0 USES**

The DeckLok bracket is used to connect deck framing elements to one another and to the building framing.

**3.0 DESCRIPTION**

**3.1 General:**

The DeckLok bracket is stamped and folded to form an L-shaped bracket with four holes in the long leg and one hole in the outstanding leg. The bracket is nominally 3 inches by 3 inches by 6 inches (76 by 76 by 152 mm). See Figure 1 for geometry and dimensions. The brackets are available in packages of twelve.

**3.2 Materials:**

The DeckLok bracket materials are described below:

**3.2.1 Part #DLHDG:** The DLHDG bracket is formed from 16 gage [base-metal thickness 0.0598 inch (1.52 mm)] steel conforming to ASTM A36. After the bracket is formed, it is hot dipped galvanized in accordance with ASTM A153-09, Class B-3.

**3.2.2 Parts #DL304SS and #DL316SS:** The DL304SS and DL316SS brackets are stamped from 16 gage [base-

metal thickness 0.0598 inch (1.52 mm)] stainless steel sheet complying with ASTM A240, Type 304 and 316, respectively.

**3.3 Fasteners:**

Bolts used with the DLHDG brackets are 1/2-inch-diameter (12.7 mm) zinc-coated bolts conforming to ASTM A307. Bolts used with the DL304SS and DL316SS brackets are 1/2-inch-diameter (12.7 mm) stainless steel bolts conforming to ASTM F593-13a, Type S30400 and S31600, respectively.

**4.0 DESIGN AND INSTALLATION**

Installation of DeckLok brackets must comply with this report and the manufacturer's published installation instructions. The manufacturer's published installation instructions must be available at the jobsite at all times during installation.

DeckLok brackets must be installed in a horizontal orientation. One bolt is fastened through the hole in the short leg of the bracket. Two bolts are installed in the long leg of the bracket in a diagonal relationship to one another. In cases where the end of the bracket would be flush with the end of the supporting member, a minimum 1/4-inch-thick (6.4 mm) shim must be used between the outstanding leg and the connected member, to ensure that the end distance to the nearest bolt in the supporting framing member meets the minimum code requirement. See Figure 2 for a typical installation detail.

See Table 1 for the allowable steel-strength axial tension loads for the brackets at various bracket deflections. The allowable load for the connection must be based on the adequacy of the bolts in the connected members or the capacity of the DeckLok bracket, whichever is less. The design of connections involving wood framing must be in accordance with the AF&PA National Design Specification for Wood (NDS). The design of connections involving alternative decking materials must be in accordance with the applicable ICC-ES evaluation reports.

**5.0 CONDITIONS OF USE**

The DeckLok Bracket described in this report complies with, or is a suitable alternative to what is specified in, those codes listed in Section 1.0 of this report, subject to the following conditions:

**5.1** Installation must comply with this report, the manufacturer's published installation instructions and the applicable code. If there is a conflict between the installation instructions and this report, this report governs.

- 5.2 Drawings, design details and calculations verifying compliance with this report must be submitted to the code official for approval. The drawings and calculations must be prepared by a registered design professional when required by the statutes of the jurisdiction in which the project is to be constructed.
- 5.3 Installation is limited to Type V-B construction (IBC) and construction permitted under the IRC.
- 5.4 When the connection design is based on an allowable deflection of the bracket of more than 0.132 inch (3.4 mm), the appropriateness of the selected deflection must be justified to the satisfaction of the code official.
- 5.5 DeckLok brackets must not be installed as hold-down (tie-down) devices.
- 5.6 The use of these brackets in contact with chemically treated wood must be approved by the code official,

since the corrosive effect of the chemically treated wood has not been evaluated.

**6.0 EVIDENCE SUBMITTED**

Data in accordance with Sections 1.0, 2.0, 3.1.1.1, 3.2.2, 3.3.1, 3.4, 4.0, and 5.0 of the ICC-ES Acceptance Criteria for Hold-downs (Tie-downs) Attached to Wood Members (AC155), dated June 2010 (Editorially revised August 2013) .

**7.0 IDENTIFICATION**

Packages of DeckLok Brackets described in this report are identified with the report holder name (Screw Products, Inc.), the product name and model number, and the evaluation report number (ESR-2114).

**TABLE 1—ALLOWABLE AXIAL LOADS FOR THE DECKLOK CONNECTOR (lbf)**

DISPLACEMENT LIMIT <sup>1</sup> (in)	DLHDG	DL304SS	DL316SS
0.132 <sup>2</sup>	625	660	660
0.200	870	985	985
0.250	1020	1200	1200
0.300	1170	1400	1400
0.350	1320	1600	1600
0.400	1500	1780	1780
0.450	1670	1980	1980
0.500	1850	2180	2180
0.600	---	2580	2580
0.700	---	2980	2980

For SI: 1 inch = 25.4 mm, 1 lbf = 4.4 N.

<sup>1</sup>The tabulated displacement consists only of deformation of the device when tested on a steel jig. Other variables contributing to total displacement, such as fastener slip and wood shrinkage, need to be checked by the connection designer.

<sup>2</sup>This is the maximum deflection of the device allowed for hold-downs at the allowable axial (steel strength) load. Since the DeckLok bracket is not intended for use as a hold-down, greater deflections may be permissible. Use of greater deflections must be justified to the satisfaction of the code official.

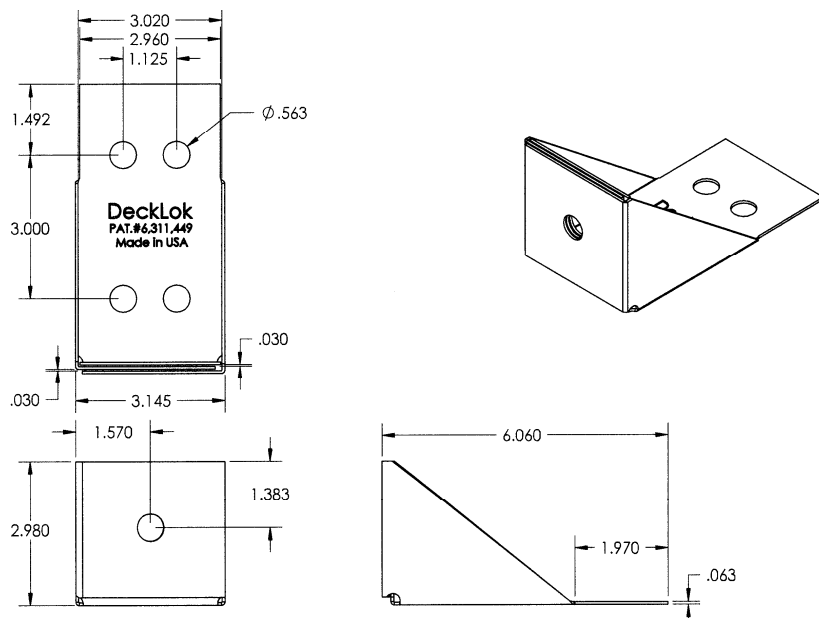

**FIGURE 1—DECKLOK CONNECTOR GEOMETRY AND DIMENSIONS**

**FIGURE 2—TYPICAL BRACKET INSTALLATION**